

150 hp Série Bleu OBD-D (7,5 ton)

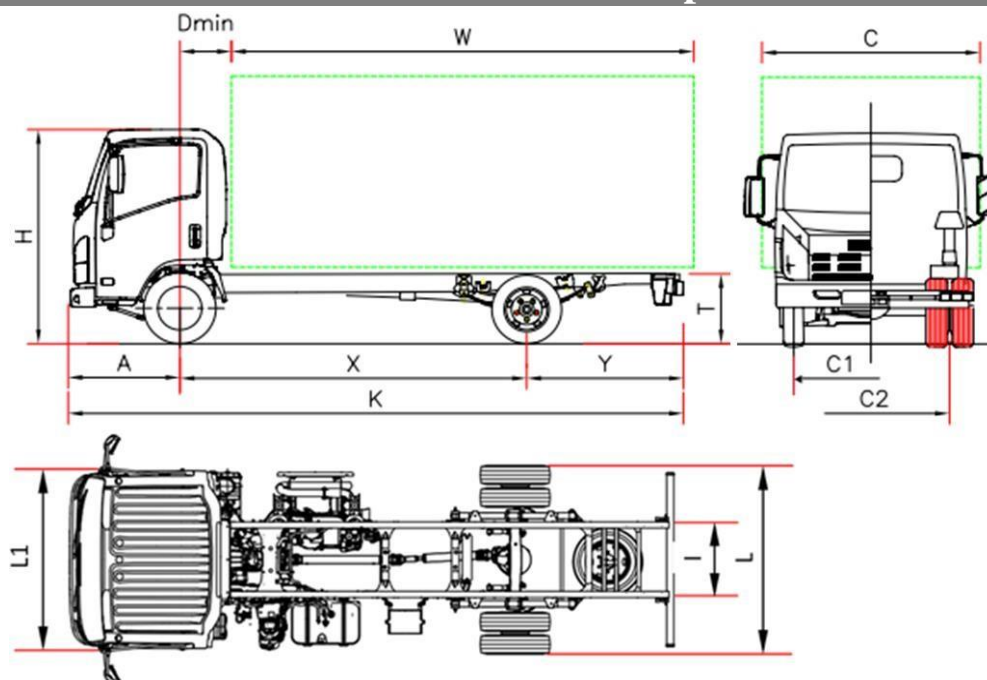

€ 42.324 VAT excluded

P 75		P 75 F	P 75 H	P 75 K	P 75 M
Wheelbase	X	2900 ⁽⁶⁾	3365	3815	4475
Overall length	K	5570	6040	6690	7870
Body length min. ⁽¹⁾	W	3750	4220	4870	6050
Body length Max. ⁽¹⁾	W	3930	4555	5185	6365
Rear overhang	Y	1560	1565	1765	2285
Chassis height	T	800			
Overall height	H	2265			
Rear axle width	L	2115			
Cab width ⁽²⁾	L1	2040			
Body width ⁽³⁾	C	2345			
Front axle to back of cab	D min	710 ⁽⁷⁾			
Front overhang	A	1110			
Frame internal size	I	850			
Front track	C1	1680			
Rear track	C2	1650			
Minimum Road Clearance	-	210			
Turning diameter (m) ⁽⁴⁾	-	11,1	12,6	14,1	16,3
WEIGHT (kg)					
Unladen weight ⁽⁵⁾		2720	2720	2740	2780
Unladen weight front axle		1750/970	1750/970	1770/970	1835/945
Gross Vehicle Weight (GVW)		7500			
Front/rear total weight		3100 / 5800			
Max trailer weight unbraked/Max trailer weight braked		750 / 3500			

1. The length of the body refers to a uniformly loaded vehicle, up to the maximum capacity on each axle (dimensions declared in C.O.C. with no chassis modifications).
2. Excluding turn signal and side mirrors
3. Possible widths with optional mirror brackets 2115/2170 – 2170/2345 – 2345/2500
4. Curb to curb turning diameter
5. The Unladen weight include spare wheel, full fuel tank and driver, optional excluded. NEES +35 Kg (25/10)
6. Wheelbase modified (see thw optional equipment)
7. NEES II 650.

P 75 - Wheelbase (mm) F 2900 - H 3365 - K 3815 - M 4475

FEBRUARY 2021

€ 42.324 (**)

Equipment	NEES 2	€ 1290 (**)
	Right-hand drive (Wheelbase F - H NEES)	€ 1182 (**)
(**)VAT excluded		
Standard features		
<ul style="list-style-type: none"> • EGR - DPD - SCR • MID display • Engine exhaust brake • Side mirrors heated and electric 	<ul style="list-style-type: none"> • Immobilizer • Central locking with remote control • Power operated windows • Suspended seat • Fog lamps Fr and Rr 	<ul style="list-style-type: none"> • Radio DAB+ with USB • Head lamps control levelling • Day-time running lights • Steering adjustable (tilting and height) • Speed limiter (90km/h)
Optional	. Air conditioning	€ 1089 (**)
	. Wheelbase modified	Ask to your dealer
	. Body builder Controller	€ 354 (**)
Engine	ISUZU 4JJ1E6N Diesel Engine 4 cylinders. Intercooler, common-rail with direct injection Variable-geometry turbocharger DISPLACEMENT 2999 cm ³ POWER 110kW (150 hp) 2800 rpm TORQUE 375 Nm 1600 – 2800 rpm EMISSIONS REGULATIONS EURO VI OBD-D.	
Safety systems	ABS ESC (Electronic Stability Control) with ASR LDWS AEBS SRS 2 Airbag (Driver/Pass.)	
Tank	90 L	16 L Ad-Blue®
Gearbox and Final drive ratio	6 gear MYY6S – 5.979 - 3.434 - 1.832 - 1.297 - 1.000 - 0.759; Reverse 5.068; Final gear ratio 5.571 (39/7)	
Transmission control	Manual	NEES 2
Dimensions of the chassis	Width 70 mm, Height 216 mm, Thickness 6 mm	
Number of seats	3	
Axle	2 the rear one with twin wheels.	
Tires	Front 215/75 R17,5C simple. Rear 215/75 R17,5C dual.	
Brakes	Front and rear: ventilated discs with asbestos-free linings. Hydraulic system, with vacuum brake booster EEC standards with ABS, independent circuits on both axles. Drum parking brake on the transmission shaft.	
Suspensions	Front and rear: Multi semi elliptical alloy steel leaf spring. Hydraulic double acting shock absorbers.	
Electric system	Nominal voltage 24V - Generator 90A - 2 x Battery 70Ah	

N.B.: Technical and specification data are given as guide only and they can be modified at any time with no prior warning. Nor the constructor neither MIDI Europe can be considered responsible if any of this information is incorrect.